

*Design* **CEPM-16HD-XX-GC-PMT**  
Arm and Disconnect Unit for External Pole  
Mount with Permanent Mount Lowering Tool for  
Surveillance Cameras

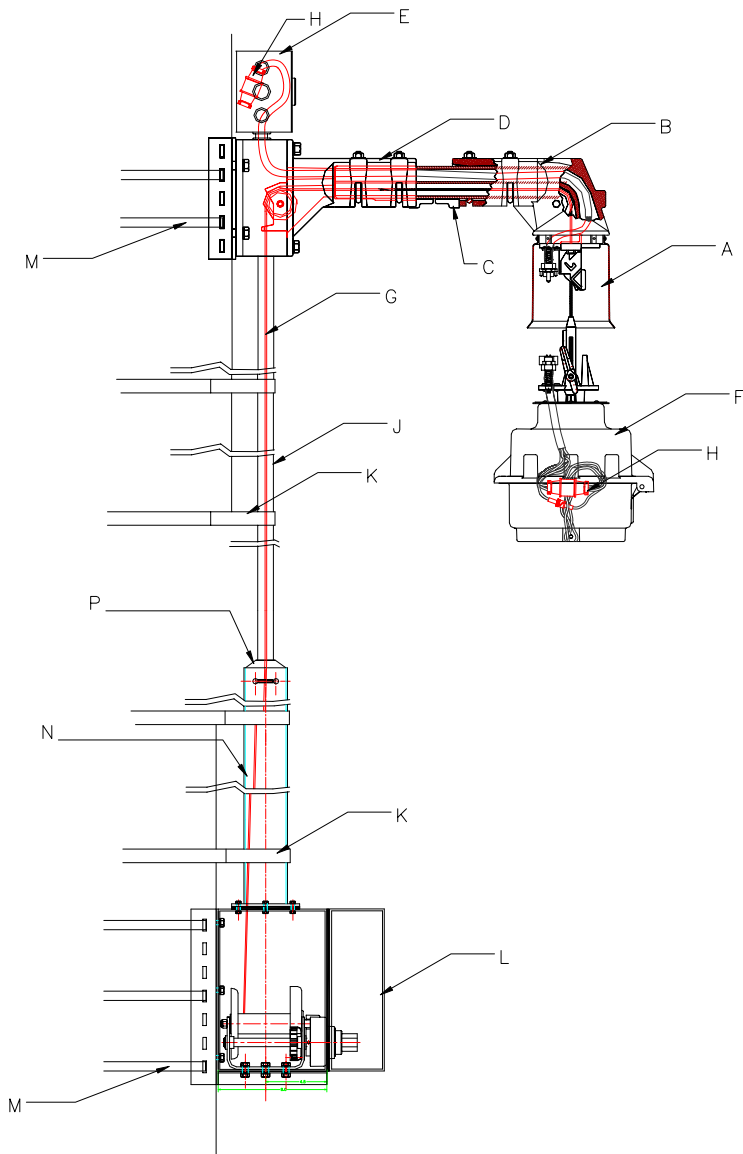

**A. ELECTRICAL AND SIGNAL DISCONNECT UNIT WITH MULTI-PIN CONNECTOR.**

**B. DISCONNECT UNIT FITTER WITH PULLEY AND U-BOLT MOUNTING.**

**C. DIVIDED PIPE ARM: 2-3/8 IN. O.D. SEPARATES CONTROL CABLE AND ELECTRICAL/SIGNAL WIRES.**

**D. POLE MOUNTED FITTER WITH PULLEY HOUSING AND MOUNTING BRACKET FOR STRAP MOUNTING TO POLE (STRAPS BY OTHERS)**

**E. ELECTRICAL CONNECTION BOX (BY OTHERS)**

**F. CAMERA CONNECTION BOX PROVIDED WITH STABILIZING WEIGHTS. EASY OPEN SWING DOWN DESIGN PERMITS QUICK ACCESS TO SIGNAL WIRES FROM CAMERA ASSEMBLY. FEATURES UNIVERSAL MOUNTING FOR ALL CAMERA TYPES AND PAN/TILT UNITS.**

**G. CONTROL CABLE CONSTRUCTED OF 5/32 INCH DIA. STAINLESS STEEL 7X19 CABLE.**

**H. STANDARD 1 PCE ELECT/SIGNAL COMPOSITE CABLE FROM DISCONNECT UNIT TO CABINET, PROVIDED BY CLS.**

**J. CONDUIT (BY OTHERS).**

**K. CONDUIT CLAMPS AS PER REQUIREMENTS (BY OTHERS).**

**L. PERMANENT MOUNT LOWERING TOOL WITH WINCH HANDLE IN MARINE GRADE #316 STAINLESS STEEL ENCLOSURE. HEAVY GAUGE STAINLESS STEEL MOUNTING BRACKET ON BASE OF CABINET. CABINET DOOR GASKETED ALL AROUND (LOCK BY OTHERS).**

**M. POLE-BELTS (BY OTHERS) AS PER REQUIREMENTS.**

**N. 316 SS 3" CONDUIT WITH ROLLER-ASSEMBLY TO ENSURE ADEQUATE FLEET-ANGLE.**

**P. SS FULL-HEIGHT WELD-ON FITTING 1-1/4" PIPE NTP INTERNAL.**

**OPTIONAL:  
GUIDE CABLE FOR TALL TAPERED POLES,  
COMMUNICATION POLES AND TOWERS.**

*Design* **CEPM-16HD-XX-GC-PMT**  
**Arm and Disconnect Unit for External Pole  
Mount with Permanent Mount Lowering Tool for  
Surveillance Cameras**

- ✚ THE CEPM SYSTEM IS AN EXTERNAL POLE MOUNT SYSTEM ALLOWING THE LOWERING SYSTEM TO BE USED ON EXISTING POLES.
- ✚ CEPM-PMT UTILIZES A PERMANENT MOUNTED GEAR BOX INSIDE A MARINE GRADE HEAVY DUTY TYPE 316 STAINLESS STEEL CABINET. THE SYSTEM ALSO PROVIDES A STAINLESS STEEL 3" PIPE, 4 FEET IN HEIGHT.
- ✚ THIS SYSTEM IS PRESENTLY BEING USED BY THE FLDOT, MIAMI DISTRICT AND ILDOT. DUE TO THE EXTREMELY CORROSIVE ENVIRONMENT, THE MARINE GRADE STAINLESS STEEL CABINET IS THE BEST TYPE OF MATERIAL FOR PROTECTING THE LOWERING TOOL FOR THE SEVERELY CORROSIVE ELEMENTS.
- ✚ THE SYSTEM COMES WITH A SINGLE PIECE COMPOSITE CABLE FROM THE DISCONNECT UNIT TO THE COMMUNICATION CABINET.
- ✚ WHEN NOT IN USE, THE WINCH HANDLE IS KEPT IN THE CABINET.
- ✚ A DRILL WITH CLUTCH CAN ALSO BE PROVIDED WITH THE SYSTEM.
- ✚ SPECIAL HEAVY DUTY BRACKET IS ALSO PROVIDED ON BASE OF CABINET AND ATTACHED TO THE VERTICAL MOUNTING BRACKET. VERTICAL BRACKET HAS SLATS FOR STRAPS TO ATTACH FRAME TO POLE.

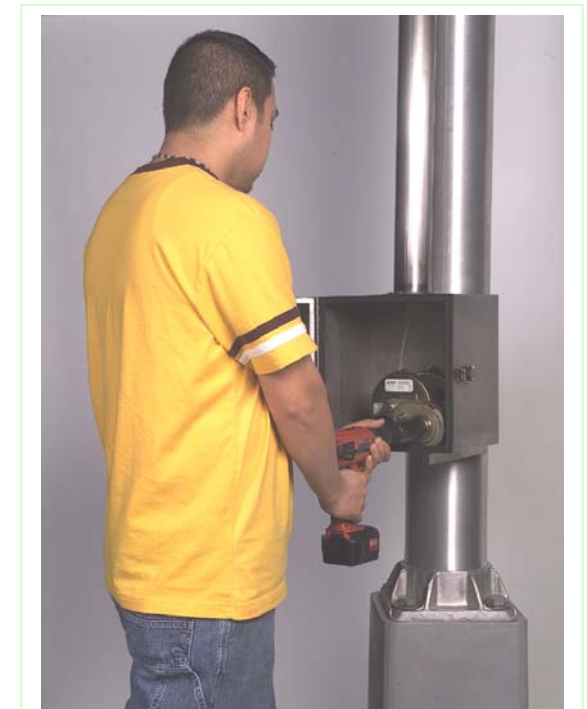

## Permanent Lowering Tool with SS Aircraft Cable **LT-DRI-CL** Drill Motor with Clutch

All gearboxes and lowering tool frames are of heavy-duty design to provide reliability, long life, and ease of operation. They incorporate solid steel heat-treated gears for maximum durability and strength. All are equipped with a special automatically actuated disc brake for better load holding ability and the prevention of the load free wheeling. They are essential for lifting operations. Also available for permanent installation or portable use indoors or outdoors for wall mounting, tower mounting, or different kinds of pole mounting.

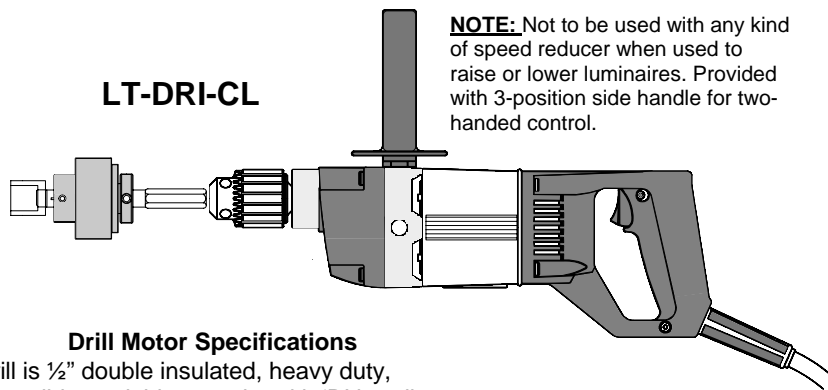

**LT-DRI-CL**

**NOTE:** Not to be used with any kind of speed reducer when used to raise or lower luminaires. Provided with 3-position side handle for two-handed control.

### Drill Motor Specifications

- Drill is ½" double insulated, heavy duty, reversible, variable speeds, with 'D' handle.
- Chuck size is ½" key chuck with key.
- Electrical-Nom. 5 amp universal motor 115v.AC
- Torque-Develops nominal 170 lbs.-in.
- Speed/HP-.5 H.P. No load speed of 350 RPM
- Overall length is 15-1/8"
- Weight: Approx. 7lbs. 6oz.

### Overload Clutch Specifications

- Lubricated ball indent-totally enclosed-adjustable torque limiting.
- Coil spring type. Varied quantities depending on torque range. Torque range: 60 to 300 lb./in.
- Winch drive is 1-1/8" hex socket with ½" sq. drive.
- Max. operating speed is 350 RPM
- Dimensions of clutch: 1 ½"Dia., 1 5/8"L. Overall, 8 ½"L
- Hub shaft: 3/8" sq. w/spring loaded pin (clutch end).
- Socket shaft: 3/8" sq. w/spring loaded retaining pin.
- Open-end wrench type torque-adjusting nut. Snap ring tool included with clutch.
- Clutch weight: 2 lbs.

### PERMANENT LOWERING TOOL



### Specifications on Lowering Tool

- Fabricated from heavy gauge steel w/black powder coat finish.
- The winch has a primer base coat followed by an enamel finish coat. Excellent resistance to corrosion.
- Oil impregnated bronze bushings and sealed ball bearings.
- All hardware is made out of stainless steel.
- The winch has a 3:1 Gear reduction to reduce the effort required to raise and lower the assembly.
- Winch comes with heavy-duty disk brake to afford greater load holding ability. This provides a positive locking mechanism to secure cable and keep from freewheeling.
- For drum capacity, see different models below.
- **Cable:** Raising & Lowering Cable for Lowering Tool. Marine grade type 316 Stainless Steel (SS) 1/8"-7x19 aircraft cable. Minimum breaking strength of 1760 lbs.
- **Dimensions:** 29"L.x8"W. With handle, 12"W.
- **Weight:** 34LBS.

\* All Lowering Systems gear boxes and lowering tools are designed for material handling usage only.  
\* Not for lifting people.  
\* Specifications subject to change without notice.